



ENVIROCAN PTY LTD

PRODUCT DATA SHEET

PRODUCT DESCRIPTION

Standard500ml (202/211)

66/52x168mm - 500ml - Aluminium Beverage Can

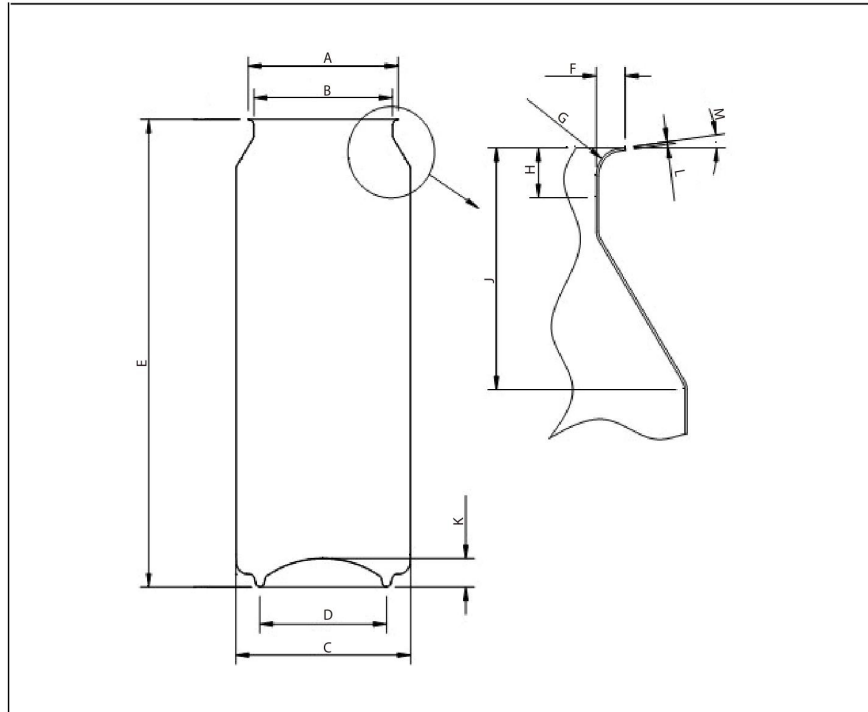

**ENVIROCAN PTY LTD
ALUMINIUM CAN BODY SPECIFICATION**

All dimensions are in millimetres and are reference unless stated otherwise.

Material	Aluminium alloy
Temper	H19
Coil Thickness	0.280 ± 0.005mm

A Flange Diameter	57.5	MAX
B Plug Diameter	52.4	± 0,30
C Body Diameter	66.2	MAX
D Base Diameter	47.34	REF
E Open Can Height	167.84	± 0,30
F Flange Width	2.08	± 0,25
G Flange Radius	1.65	REF
H Neck Seaming Clearance	3.0	MIN
J Shoulder Height	17.2	REF
K Dome Depth	10.21	
L Flange Thickness	0.175	
M Flange Angle	0-12°	

Brimful	534.8	ml
Axial Load	800	N MIN
Dome reversal	610	kPa MIN

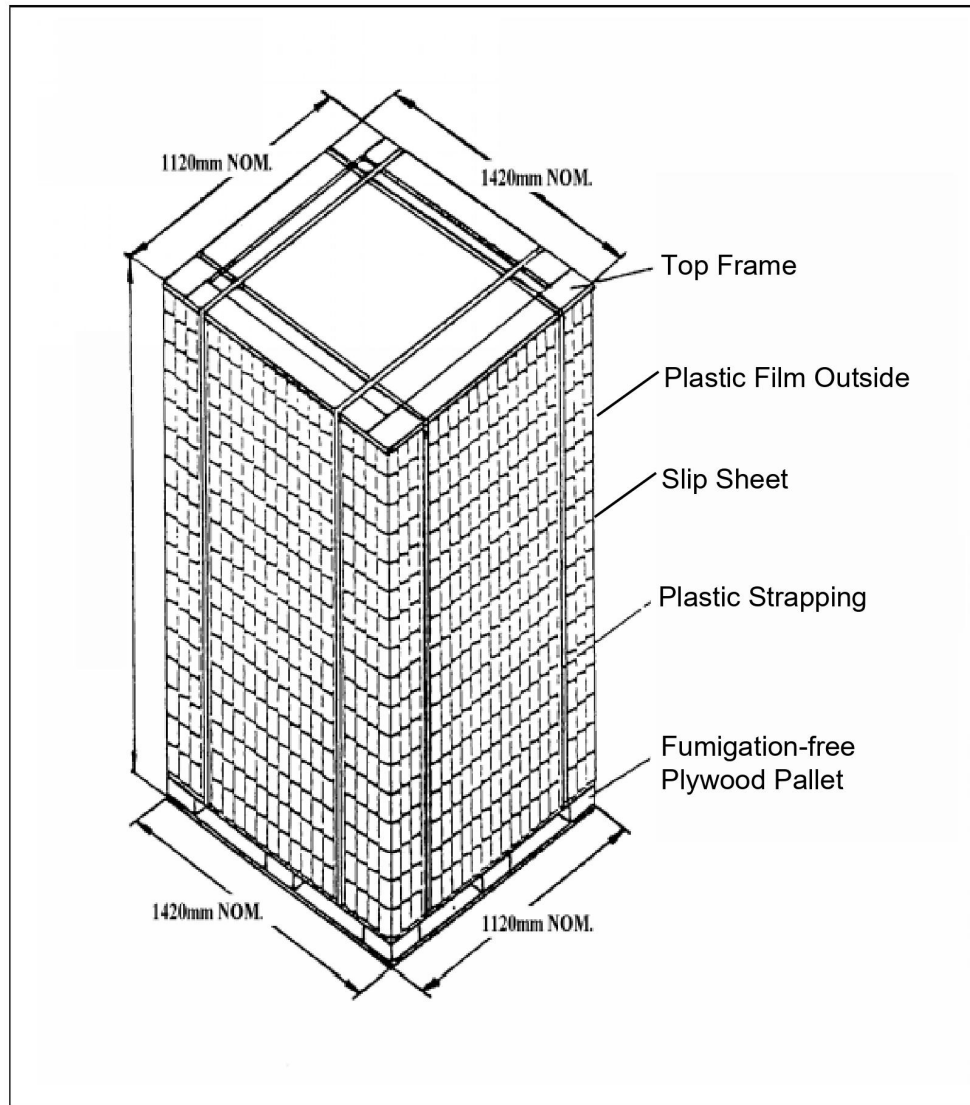

Standard 500ML Aluminum Cans Packaging Specification

The packaging of the cans must be on a pallet with 389 cans, separated with a slip sheet, fumigation-free plywood pallet, frame on top, wrapped with plastic film and secured with plastic strapping. See attached image.

14 Levels
389 Cans per Level
5446 Cans per pallet
16 Pallets per 40HQ Container

Fumigation-free plywood pallet size:
W1120mm*L1420mm*H2482mm

Net Weight: 75kg REF
Gross Weight: 110kg REF